

24 Jul 96 TP6 and TP9 Deleted
 26 Sep 96 Delete 4.7K Pin B(F) to Gnd
 27 Sep 96 Change 27Ω pin 30 of IC4 to 18 Ω
 30 Sep 96 Add 49.9K IC7 pin 3 to Gnd
 Add 49.9K IC8 pin 2 to Gnd
 28 Sep 98 Replace hysteresis diodes of
 comparators with 0.1μf caps
 04 Jan 02 Change gain of IC2 to 20,
 change 10Ω +15V safety resistor
 5 Ω.

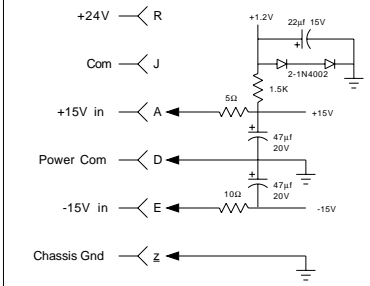
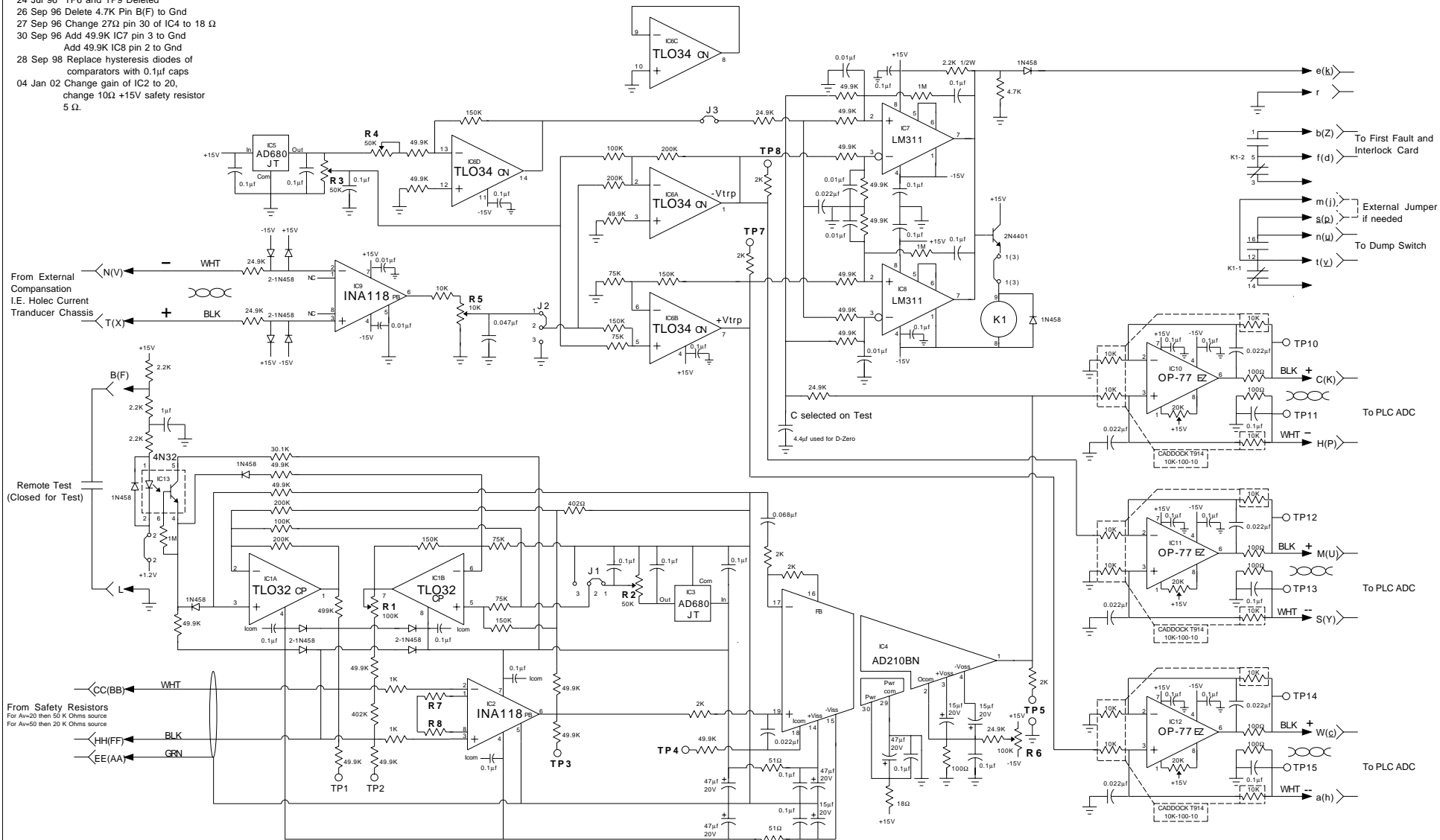

Measured Frequency Response and Noise Levels
 with 200 ft. RG-108 cable on input
 with 20 K Ohms source resistance,
 rise time measured from 10% to 90%
 of output with square wave input:

TP5, 7 mVp-p 25 KHz noise
 -3 DB @ 1 KHz
 -6 DB @ 1.65 KHz
 rise time = 400 μSec

IC8, pin2, 1mVp-p 25 KHz noise
 -3 DB @ 165 Hz
 -6 DB @ 240 Hz
 rise time = 3 nSec

TP10 to TP11, 2 mVp-p 25 KHz noise
 -3 DB @ 350 Hz
 -6 DB @ 660 Hz
 rise time = 800 μSec

Note:

- For IC2 Av=20 then R7=2.49 KΩ, R8=150 Ω
- For IC2 Av=50 then R7=1 KΩ, R8=20 Ω
- TP3,TP4,TP5,TP7, and TP8 are external test points,
 all the rest of the test points are internal.
- Bracketed NIM pin assignments are for Channel B,
 all others are for Channel A or common to both
 channels

K1-C.P.Claire LX200E00
 R1-Common Mode adjustment
 R2- +5V Offset adjustment
 R3-Trip Level Reference adjustment
 R4-Offset Null to comparator
 R5-External Compensation Level adjustment
 R6-Offset Null of Iso-Op-Amp

Reference to FNAL Drawing No.:
 3823-111-ED-330052
 Sheet 5 of 17

Originator: W. Jaskierny
 Drawn by: W. Jaskierny
 Originated: 06 Dec 1995
 Last Revision: 04 Jan 2002
 Issued: 19 Jun 2002

				Fermilab Particle Physics Division Site Support Group	
				Title Isolation Amplifier and Level Detector (1 channel)	
Size	FSCN No	DWG No	Rev		
A	U of Ill NPL				
Scale	Project	G Zero	Sheet	3 of 7	